

Abstract: Small Rocket Payload Power Distribution

The Student Space Programs Lab, Penn State University

Spring 2013

For the Student Space Programs Lab, I designed and fabricated the 2013 Student Training Program's power distribution system. This system, a small rocket payload, required a 5V rail and a 3.3V rail to power the onboard processor and sensors. Further, this system required voltage and current monitoring. A 3.7V LiPo battery was provided as the power source. To supply the 5V rail, a COTS boost converter was selected from Pololu. To supply the 3.3V rail, the voltage needed to first be stepped up to 5V then stepped back down to 3.3V. This occurred because 3.7V was just below the threshold where the linear regulator would be able to reliably regulate 3.3V. While not energy efficient, this design used the components at hand saving money and shipping time. To monitor the current leaving the battery, a current sensor was selected and placed in series with the battery's positive terminal. To monitor the voltage across the battery, a voltage divider to scale the 3.7V output to 3.3V was selected as to not exceed the provided ADC's 3.3V maximum rating. The output of both the voltage divider and the current sensor were then sampled by the onboard computer's ADC. A driver was written to read the ADC data for both sensors, convert the samples to their respective values, and return the voltage and current readings for subsequent monitoring and logging. The included code also toggled a MOSFET to enable burn wire to disengage the payload from its parachute and snippet of code to read from a button to determine if the payload is inside or outside of the rocket.

The remainder of this section includes:

- Pictures of the payload and the system's CAD model

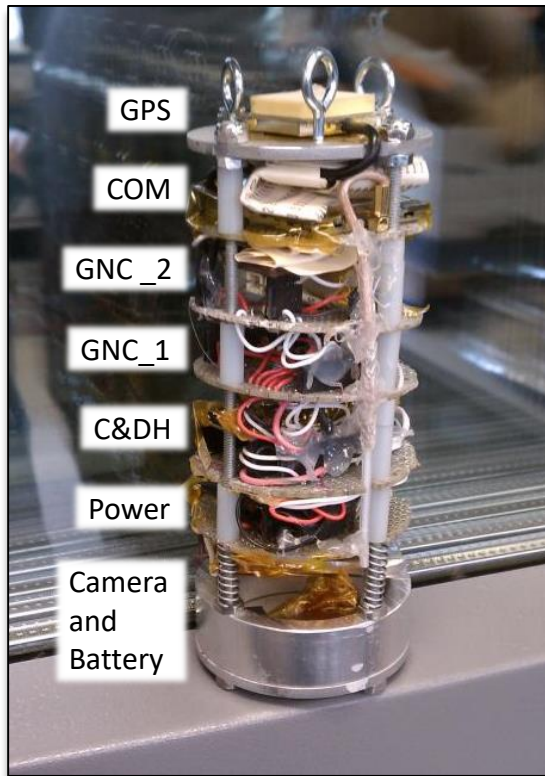

A front view of the payload sans parachute. The layers are labeled.

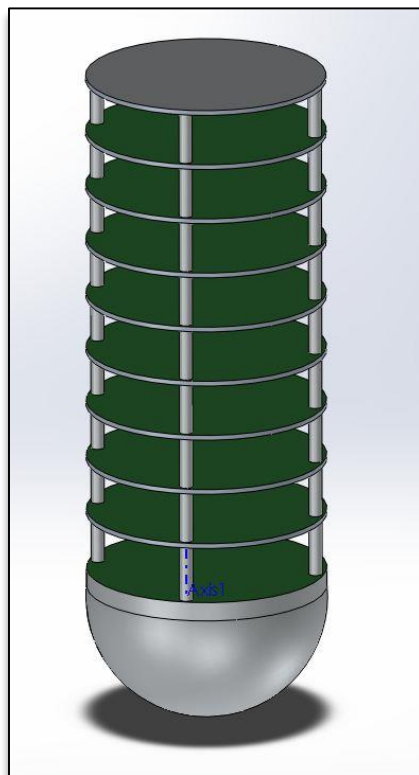

Two different views of the CAD model of the payload.

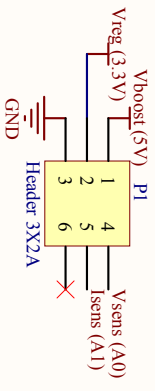
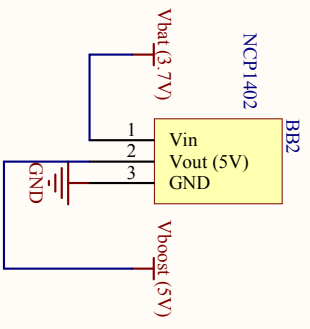
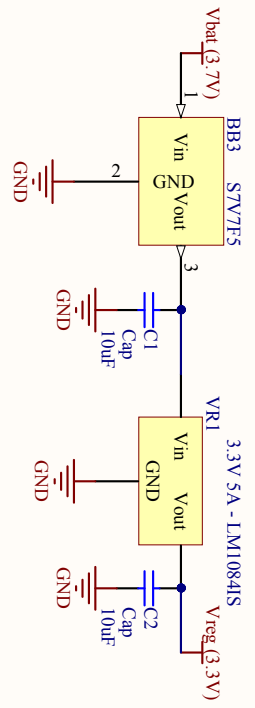
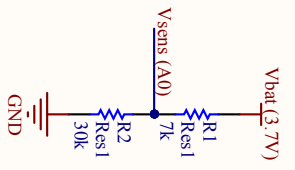
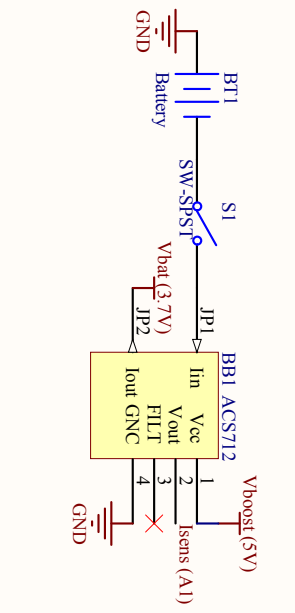

Title
Power Board for STP 2013 Payload - Final Revision

Size	Number	Revision
A		

Date: 1/10/2016
 File: P:\STP...\PWR Schematic Rev2.SchDoc
 Sheet of
 Drawn By: Chris Miller

```
// PowerDrivers.cpp
// Christopher Miller
// The Student Space Programs Lab
// Power subsystem drivers; reads voltage and current ADC values
// Converts values from counts to the proper units
// Toggles burn MOSFET and reads insertion switch

#include "mbed.h"
#include "PowerDrivers.h"
#include <math.h>

/***** pin assignments *****/
#define pin_burn_ENABLE    p21 //Burn Coil switch
#define pin_v_SENS        p16 //voltage analog in
#define pin_i_SENS        p17 //current analog in
#define pin_rel_BTN       p25 //release button switch

AnalogIn v_SENS(pin_v_SENS); //Voltage Sensor
AnalogIn i_SENS(pin_i_SENS); //Current Sensor
DigitalOut burn_enable(pin_burn_ENABLE); //BurnCoil
DigitalOut rel_BTN(pin_rel_BTN); // release button

/*****FUNCTIONS*****/

void MOSFET(int onoff){ //turns on or off a MOSFET, pass 1(on) or 0(off)
    burn_enable.write(onoff);
    wait(.1);
}

float VoltageSens(){ // read the voltage sensor, returns values from 0 to 3.3
    float output = 0;
    output = 5*v_SENS;
    return output;
}

float CurrentSens(){ //Reads the current, returns values from
    float output = 0;
    output = 5.416*(3.3*i_SENS)-13.556; // Tested function, characterized
    //output = ((i_SENS*5)-2.5)/.185;
    return output;
}

int ReleaseState(){
    if(rel_BTN.read() == 1)
        return 0; // while high, return 0 meaning still in rocket
    else
        return 1; // if its low, return 1, meaning out of rocket
}
```